

REFLECTION
LEDKO™ EXT
with dual gobo rotator

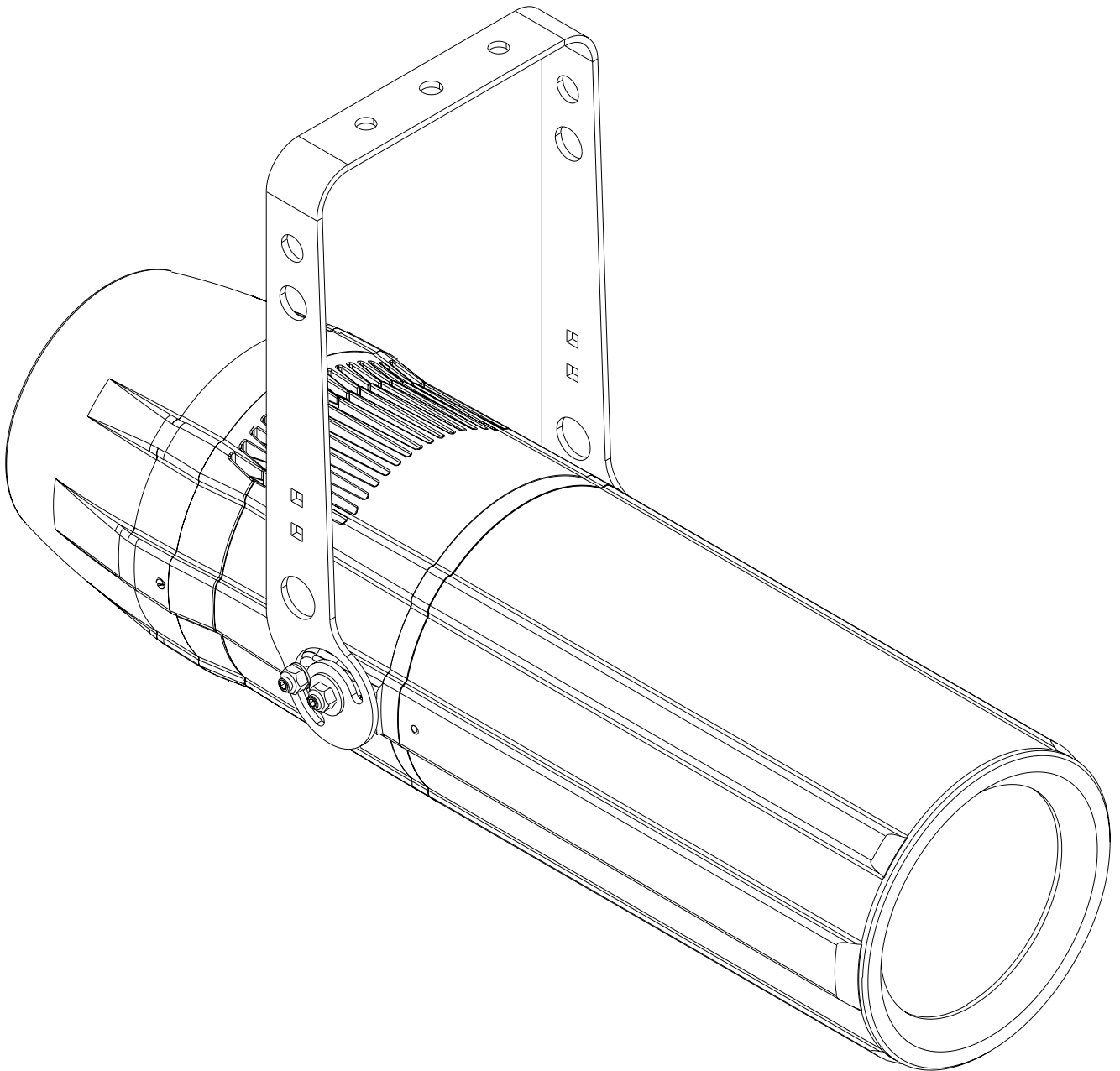

REFLECTION **LEDko**™ **EXT**

with dual gobo rotator

Serial Number:

.....

Purchase date:

.....

Dealer:

.....

Address:

.....

Suburb:

.....

Country:

.....

Phone / Fax:

.....

Please note in the space provided above the relative service information of the model and the retailer from whom you purchased your **LEDko EXT**: this information will assist us in providing spare parts, repairs or in answering any technical enquiries with the utmost speed and accuracy.

WARNING: the security of the fixture is granted only if these instructions are strictly followed; therefore it is absolutely necessary to keep this manual.

Index

1. Packaging and transportation	Pag. 5
1.1 Packaging	Pag. 5
1.2 Transportation	Pag. 5
2. General information	Pag. 5
2.1 Safety informations	Pag. 5
2.2 Warranty conditions	Pag. 6
2.3 EC norms	Pag. 6
3. Product specifications	Pag. 7
3.1 Technical characteristics	Pag. 7
3.2 Dimensions.....	Pag. 7
3.3 Unit's main components	Pag. 8
3.4 Back panel description	Pag. 9
4. Installation	Pag. 10
4.1 Mechanical installation	Pag. 11
4.2 Safety chain	Pag. 11
4.3 Adjusting unit's tilt	Pag. 11
4.4 Optic group, framing system and gobos	Pag. 11
4.5 How to remove the 'Dual gobo rotator'	Pag. 12
4.6 How to mount the four blade framing system	Pag. 12
4.7 How to insert the glass/metal gobo	Pag. 13
5. Powering up	Pag. 14
5.1 Operating voltage and frequency	Pag. 14
5.2 Connection to mains power	Pag. 14
6. Control signal connections	Pag. 15
6.1 Control signal connection by XLR5 plugs	Pag. 15
7. Turning on the projector	Pag. 16
7.1 DMX address of the unit	Pag. 16
8. DMX Chart	Pag. 17
8.1 DMX Chart 5 or 1 channels	Pag. 17
9. Display panel functions	Pag. 20
9.1 Quick guide to menu	Pag. 20
9.2 Rapid count	Pag. 20
9.3 Quick dimmer menu	Pag. 21
9.4 Main functions menu	Pag. 22
9.5 Measure (MEAS)	Pag. 24
9.6 Electronic alignment of the LEDs	Pag. 26
9.7 Special functions of the fixture	Pag. 27
9.8 Error messages	Pag. 27

10. Spare parts	Pag. 28
11. Maintenance	Pag. 28
11.1 Firmware update	Pag. 28
11.2 Periodic cleaning	Pag. 28
11.3 Periodic controls	Pag. 28
11.4 Fuses	Pag. 28
12. F.A.Q. and answers	Pag. 29

Congratulations on having purchased a **Coemar** product. You have assured yourself of a fixture of the highest quality, both in componentry and in the technology used. We renew our invitation to you to complete the service information on the previous page, to expedite any request for service information or spares (in case of problems encountered either during, or subsequent to, installation). This information will assist in providing prompt and accurate advice from your **Coemar** service centre. Following the instructions and procedures outlined in this manual will ensure the maximum efficiency of this product for years to come.

1. Packaging and transportation

1.1 Packaging

Open the packaging and make sure that no part of the equipment has suffered any damage during the transportation. In case of damage to the fixture, contact your carrier and your supplier immediately by telephone, fax or email, and inform them you will formally notify them in writing through registered letter.

Packing list

Ensure the packaging contains:

- 1 LEDko EXT**
- 1 Instruction manual**

1.2 Transportation

The **LEDko EXT** should be transported in either its original packaging or in an appropriate flight case.

2. General information

2.1 Safety informations

Fire prevention:



- 1.** Never locate the fixture on any flammable surface.
- 2.** Minimum distance from flammable materials: 0,5 m.
- 3.** Minimum distance from the closet illuminable surface: 0,5 m.
- 4.** Replace any blown or damaged fuse only with those of identical values. Refer to the schematic diagram if there is any doubt.
- 5.** Connect the projector to mains power protected by a thermal magnetic circuit breaker.

Prevention from electric shock:



- 1.** Presence of high voltage inside of the fixture. Insulate the projector from mains supply before opening or performing any function which involves touching the inside of the fixture, including lamp replacement.
- 2.** For the connection to the mains, adhere strictly to the guidelines outlined in this manual.

3. The level of technology of **LEDko EXT** requires the use of specialised personnel for all service applications; refer all work to your authorised **Coemar** service centre.
4. A good earth connection is essential for the proper functioning of the projector. Never connect the fixture if there is no earth connection.
5. Mains cables must not come into contact with other cables.
6. Do not operate the projector with wet hands or in an area where water is present.
7. The fixture must never be located in an exposed position, or in areas of extreme humidity.

Safety:



1. The projector must always be installed with bolts, clamps, or other fixing devices which are suitably rated to support the weight of the projector.
2. Always use a secondary safety fixing device with chain or steel wire of a suitable rating to sustain the weight of the unit in case of failure of the principal fixing point.
3. The external surfaces of the unit, at various points, may reach 60°C. Never handle the unit until at least 10 minutes have elapsed since the LED was turned off.
4. Never install the fixture in an enclosed area lacking sufficient air flow; the room temperature must not exceed 35°C.
5. The projector contains electronic and electrical components which must under no circumstances be in contact with water, oil or any other liquid. Failure to do so will compromise the proper functioning of the projector.

2.2 Warranty conditions

1. The fixture is under warranty for 36 months from the purchase date against factory defec-tions.
2. Damage ought to unskillfulness, inappropriate use, or lack of suggested maintenance are excluded from the warranty.
3. Warranty expires when the projector is opened by unauthorized personnel.
4. Warranty doesn't include the replacement of the fixture.
5. Serial number and model of the fixture are necessary to retrieve informations and assistance from the dealer.

2.3 EC Norms

The projector meets all fundamental applicable EC requirements.

3. Product specifications

3.1 Technical characteristics

Power supply	85-264 V, auto-sensing, 50/60 Hz
Maximum current	0.96 A at 230 V, 1.92 A at 115 V
Power factor	$\text{Cos}\phi = 0.95$
Max power consumption	210 W
Color temperature	Tungsten: 3.200 K - Daylight: 5.600 K
Color Rendering Index (CRI)	D and T models: CRI 80, CRI 90
Weight	14.0 Kg - 30.8 lbs
Storage temperature	from - 40° C / -40° F to + 85° C / +185° F
Operating temperature	from - 40° C / -40° F to + 40° C / +104° F
IP rating	65

3.2 Dimensions

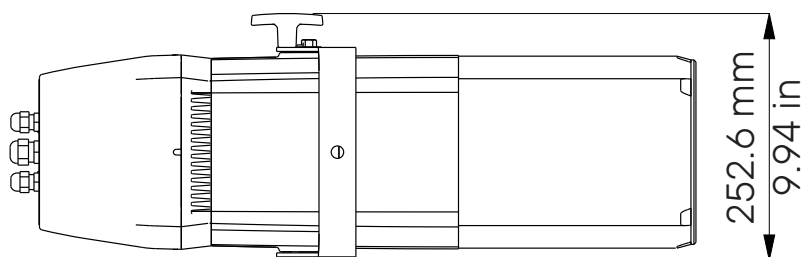
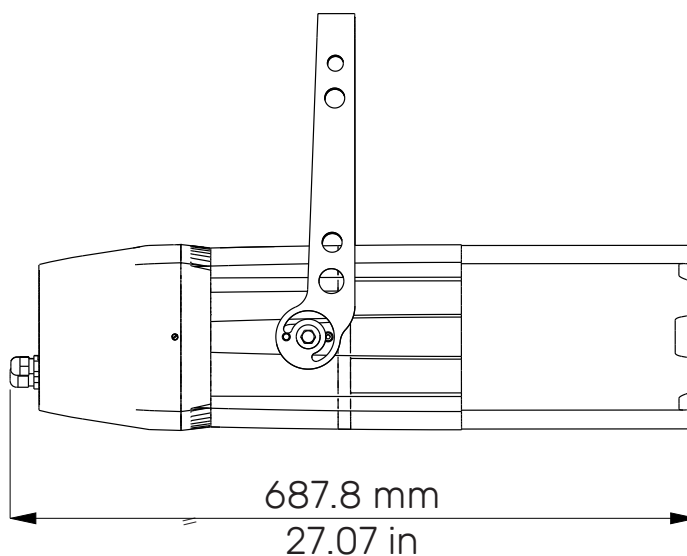
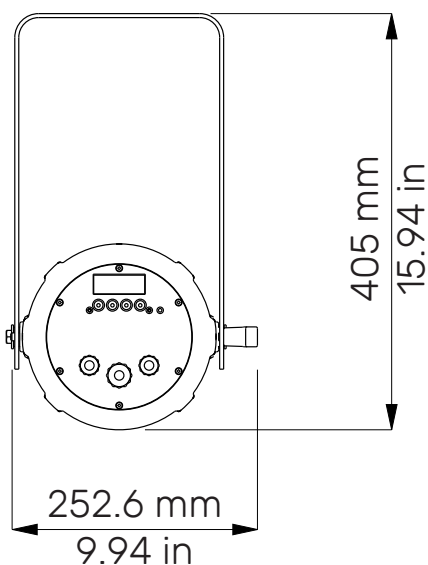

3.3 Unit's main components

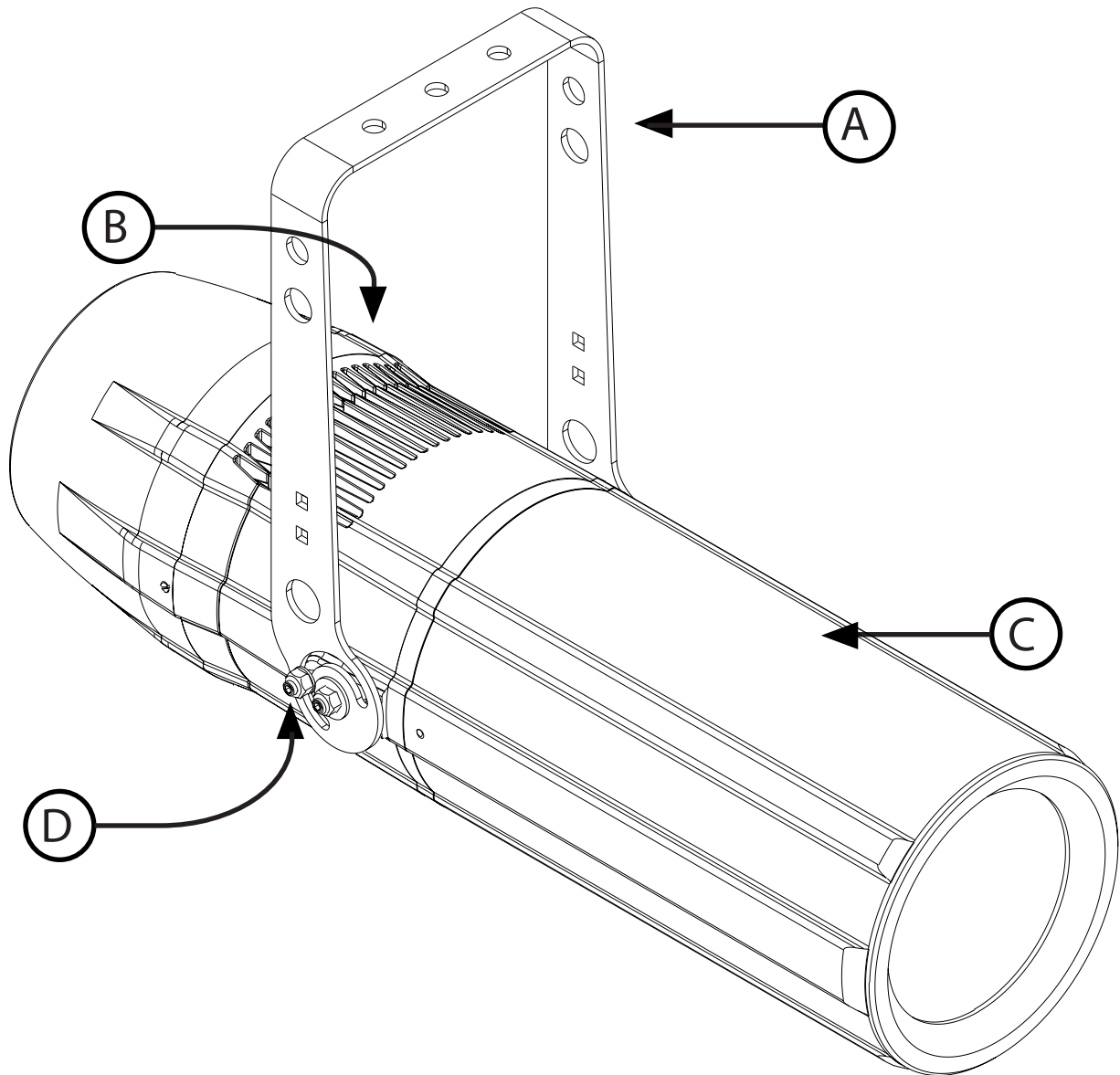

Components description	
A	Yoke with mounting holes
B	Cooling unit
C	Optical holder tube
D	Locking screw for yoke

3.4 Back panel description

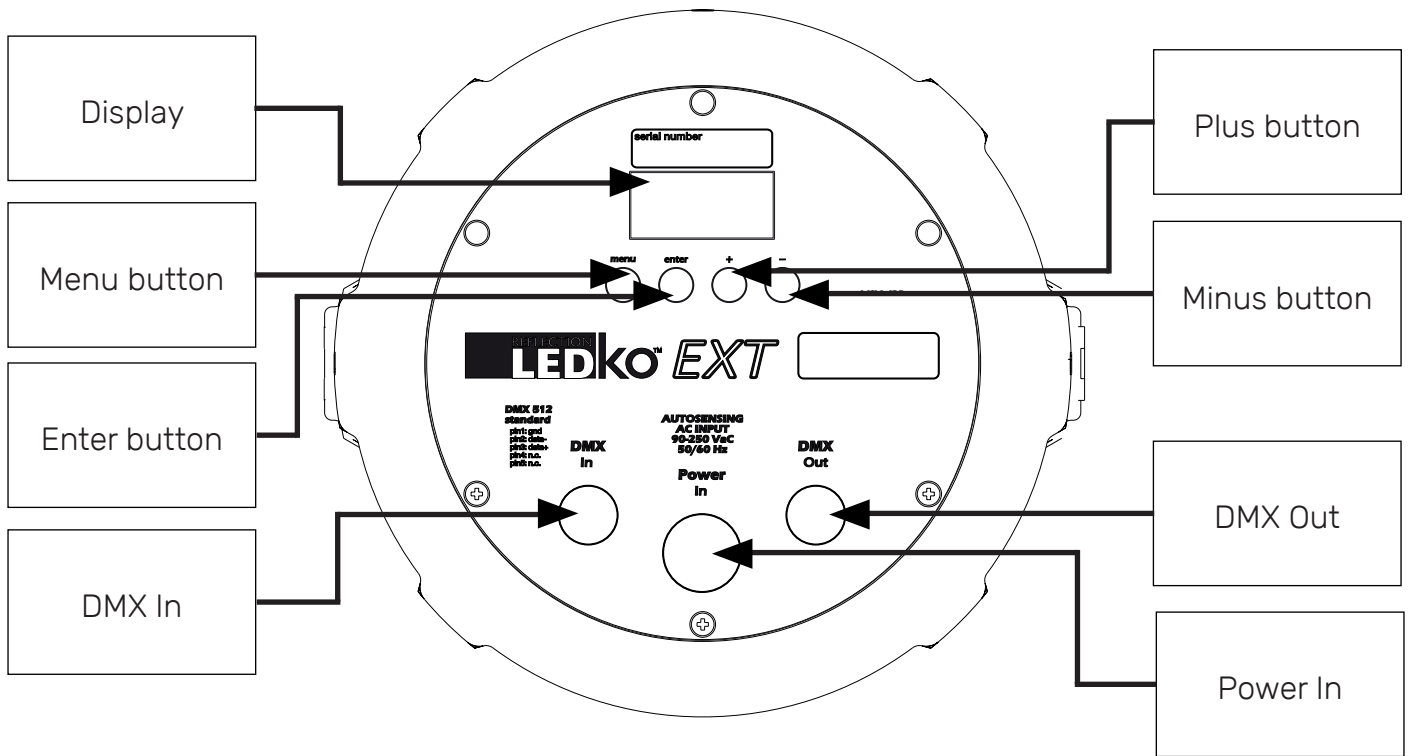

4. Installation

4.1 Mechanical installation

LEDko EXT may be hung from an appropriate structure in any position or on tripod. If hanging the fixture from a lighting truss or similar, we recommend the use of an appropriate clamp "A", as shown in the following diagram.

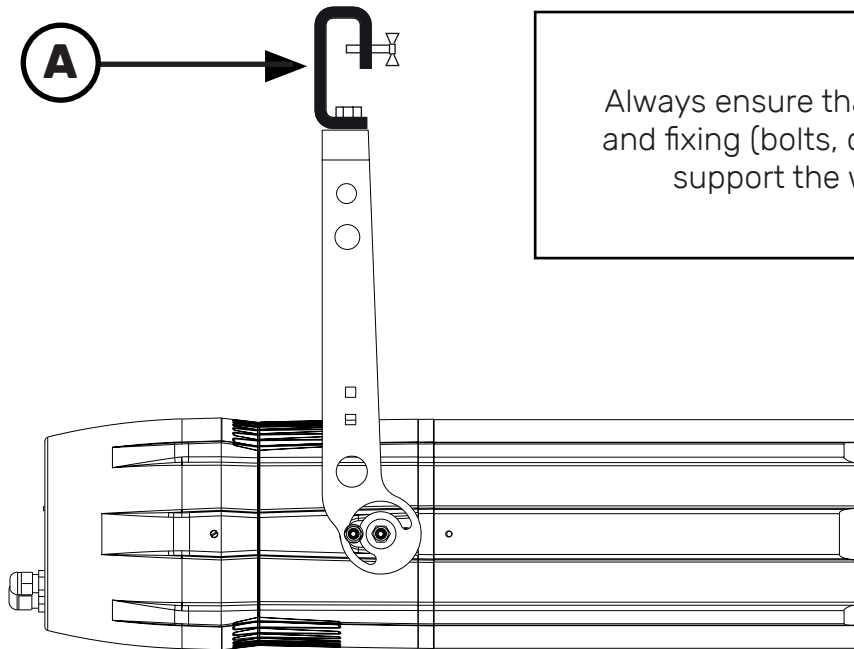

Always ensure that your support structure and fixing (bolts, clamps, etc...) are rated to support the weight of the fixture.

4.2 Safety chain

When hanging **LEDko EXT** it is recommended to use a safety chain, as required by current legislation. The safety chain must pass through the handles of the unit and then attached to the structure.

If using steel cables and chains not **Coemar's** production, make sure they are suitable to support the weight of the unit according to normative UL/ETL (required: the weight of 6 complete devices for at least one hour).

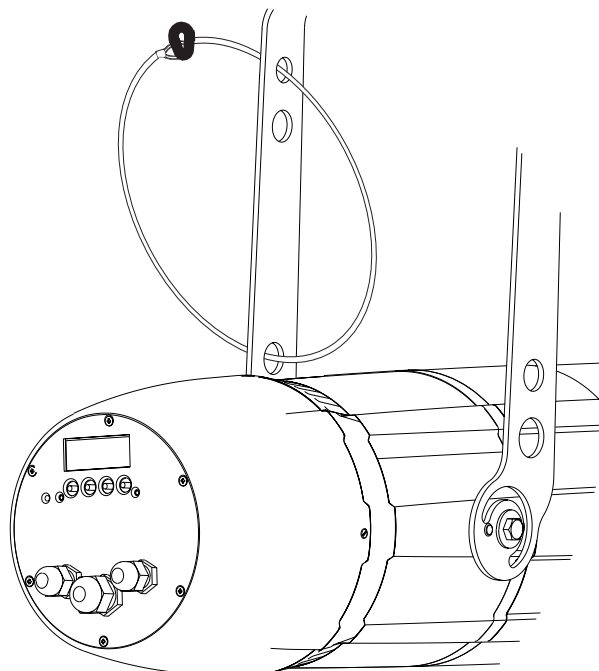

4.3 Adjusting unit's tilt

1. In order to adjust the tilt of the unit simply loose the side screw "B" on the yoke, adjust the tilt and lock the yoke by tightening the screw again.

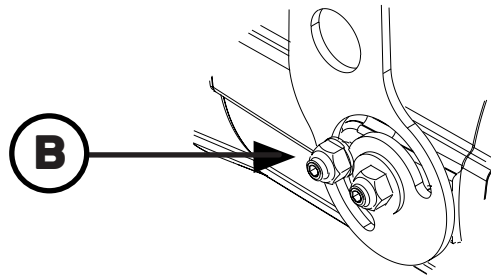

4.4 Optical group, framing system and gobos

Follow these steps in order to configure the optical group properly:

1. Remove the two screws "C" placed on both sides of the optical holder tube;
2. Gently remove the optical holder tube "D" pulling it away from the body;

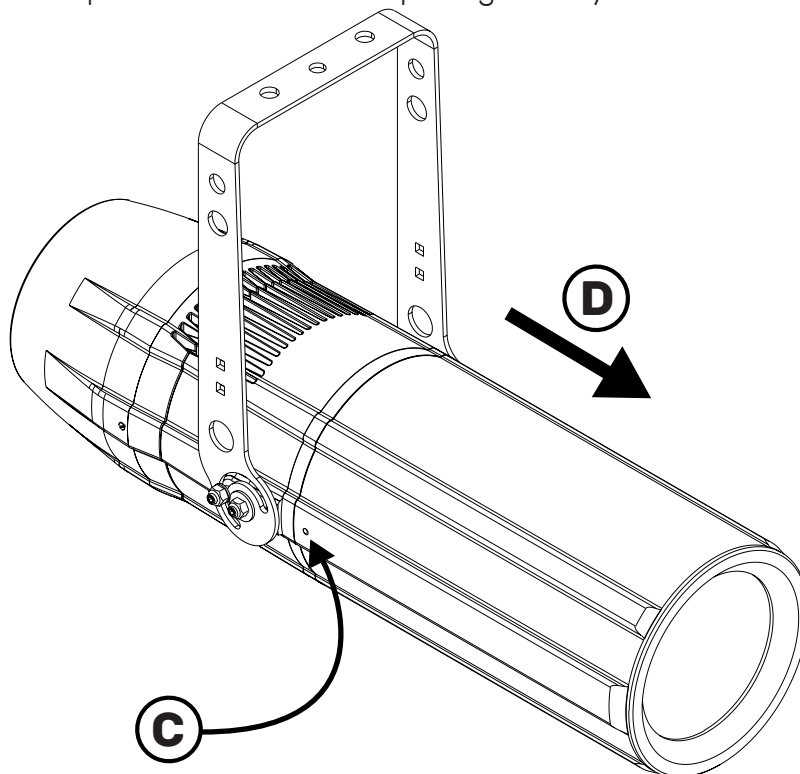

3. Loose the thumbscrews "E" of the two lenses to set them at desired position. Turn on the fixture and check if the desired focus and zoom lever are correct, then tighten the thumbscrews;

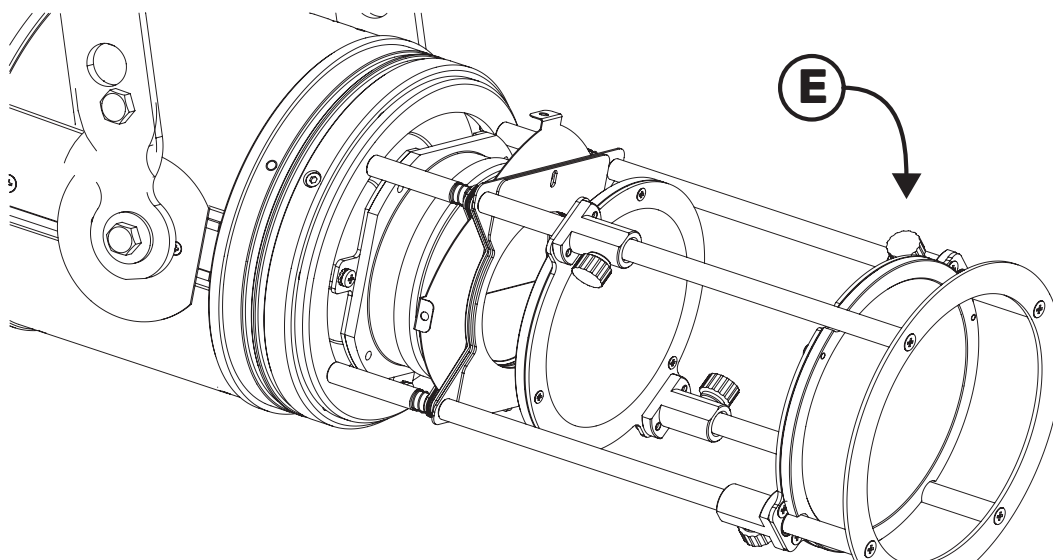

4.5 How to remove the 'Dual gobo rotator'

When you will receive **LEDko EXT**, the dual gobo rotator will already be installed in the projector "F"; then follow the instructions below to remove it:

Once the optical tube holder has been removed, disconnect the plug that connect the motors to the **LEDko EXT** body, unscrew the screws "G", pull the dual gobo rotator up by one/two centimeters, incline it "H" until it can be removed from the optical group

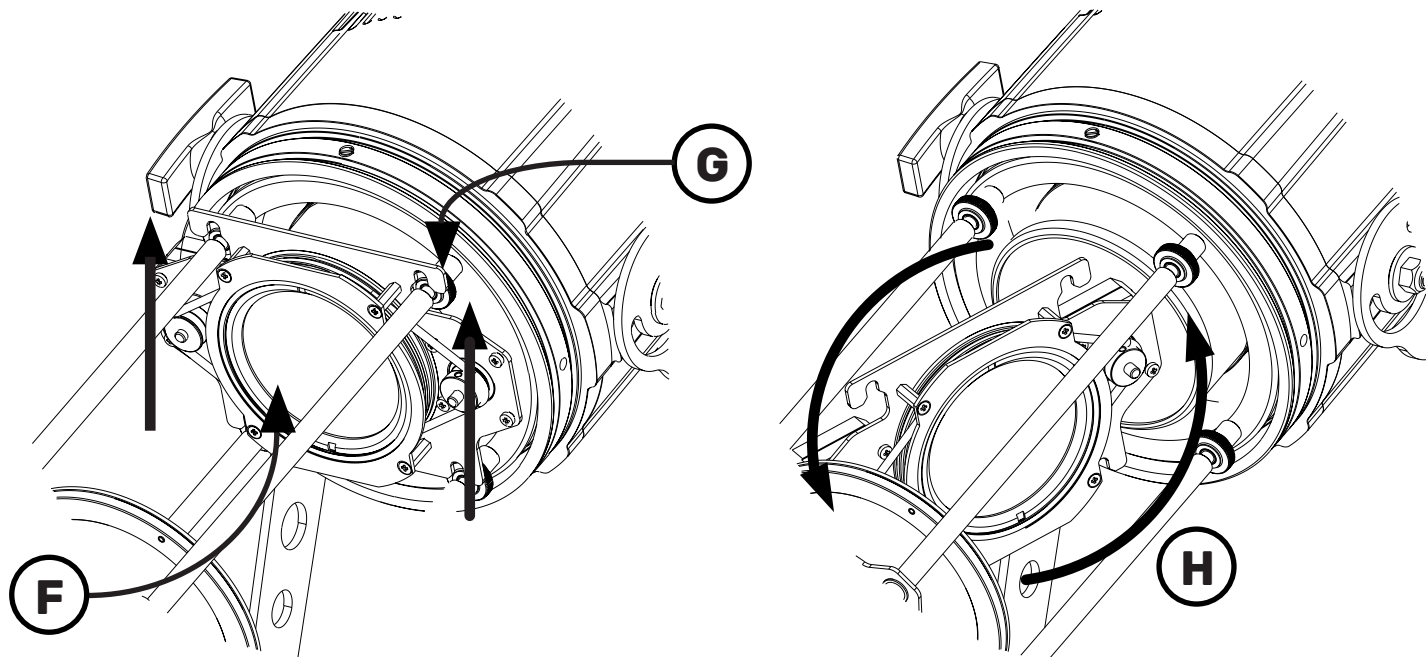

4.6 How to mount the four blade framing system

Once the dual gobo rotator has been removed, the four blade framing system can be inserted. Incline the four blade framing system "I", insert it into the optic group, place it in the appropriate slot and screw the previously unscrewed screws "J".

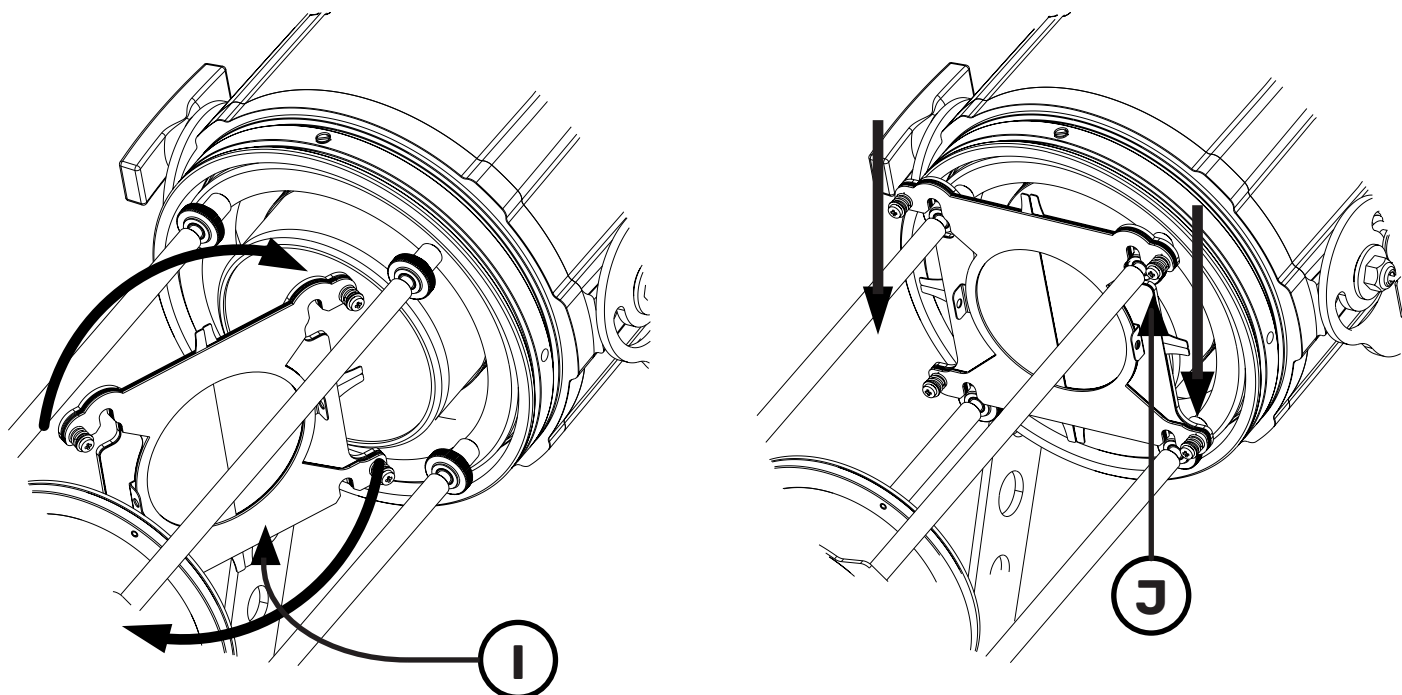

4.7 How to insert the glass gobos

To insert one or two (glass or metal) gobo, follow the 4.5 paragraph to remove the dual gobo rotator; then screw off the metal rings "K" that will keep the gobo steady with the provided key "L"; follow the same steps if you want to mount a second gobo on the back. Once removed one or both the rings, place your gobo "M" at will. Done this, proceed with the re-closing the dual gobo rotator. Then place the rings in the appropriate slot and re-tighten until the gobo is well fixed. At this point reinsert the dual gobo rotator keeping it slightly inclined "N" so that it can enter in the optical group and fix it in the slot. Finally reconnect the plug that goes from the motors of the dual gobo rotator to the body of the **LEDko EXT**. At this point following the DMX chart you should be able to move your gobo at your convenience.

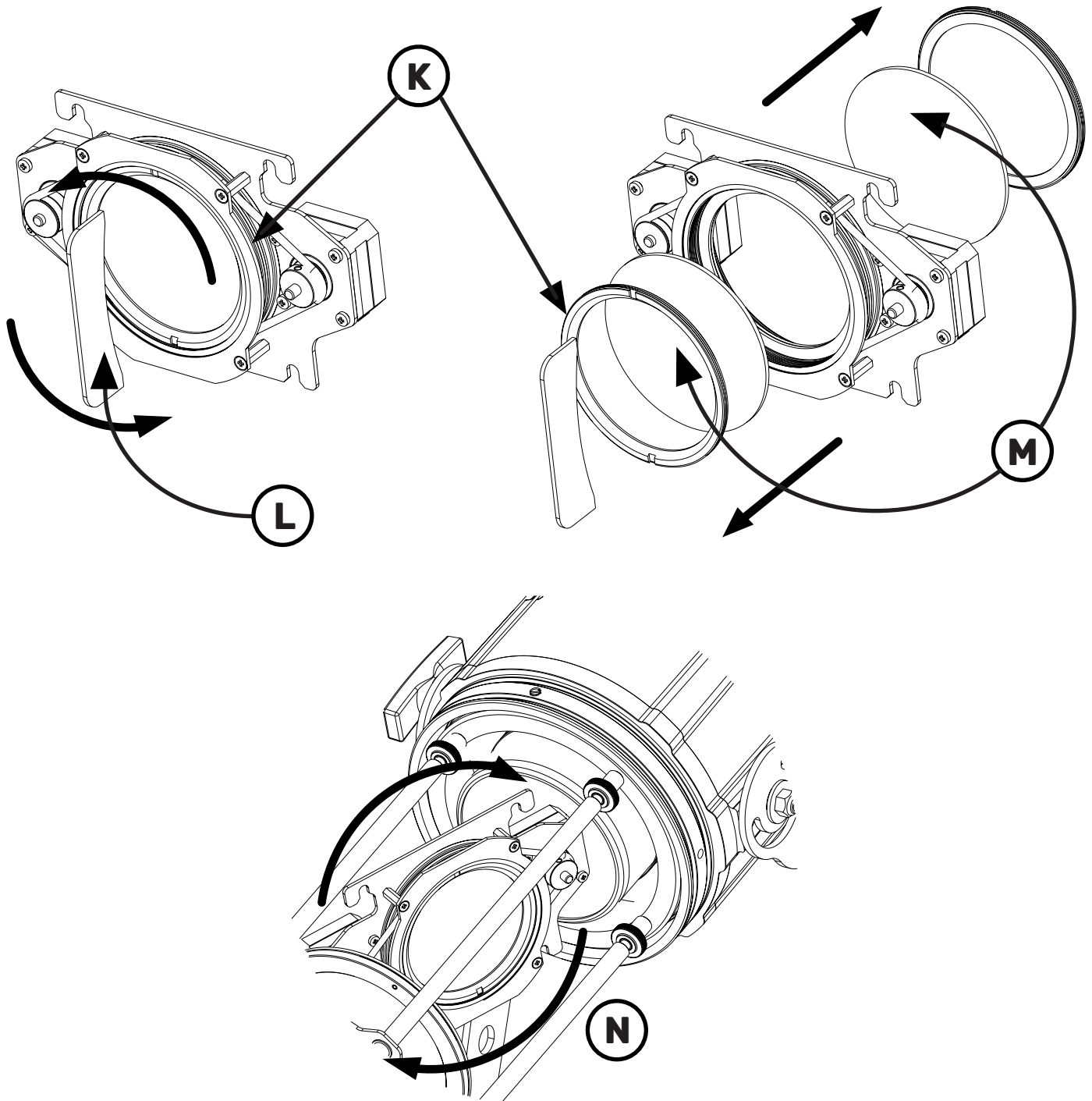

5. Powering up

5.1 Operating voltage and frequency

The unit may operate at voltage ranges from 85 to 264 V at a frequency of 50 or 60 Hz. It is not needed to effect any setup procedures: **LEDko EXT** will automatically adjust its operation to suit any frequency or voltage within this range.

5.2 Connection to mains power

Mains cable characteristics

The mains cable provided is thermally resistant, complying to the most recent International standards.

Note: in case of cable replacement, similar cable with comparable thermal resistant qualities must be used exclusively (cable 3 X 1,5 ø external 10 mm, rated 300/500V, tested to 2 KV, operating temperature -40°C + 180°C, Coemar cod. CV5311).

Connection to mains power

LEDko EXT is equipped with an internal cable without power plug.

The max absorption of **LEDko EXT** is reported in the following table:

- 230 V 0.96 A constant during normal exercise.
- 115 V 1.92 A constant during normal exercise.

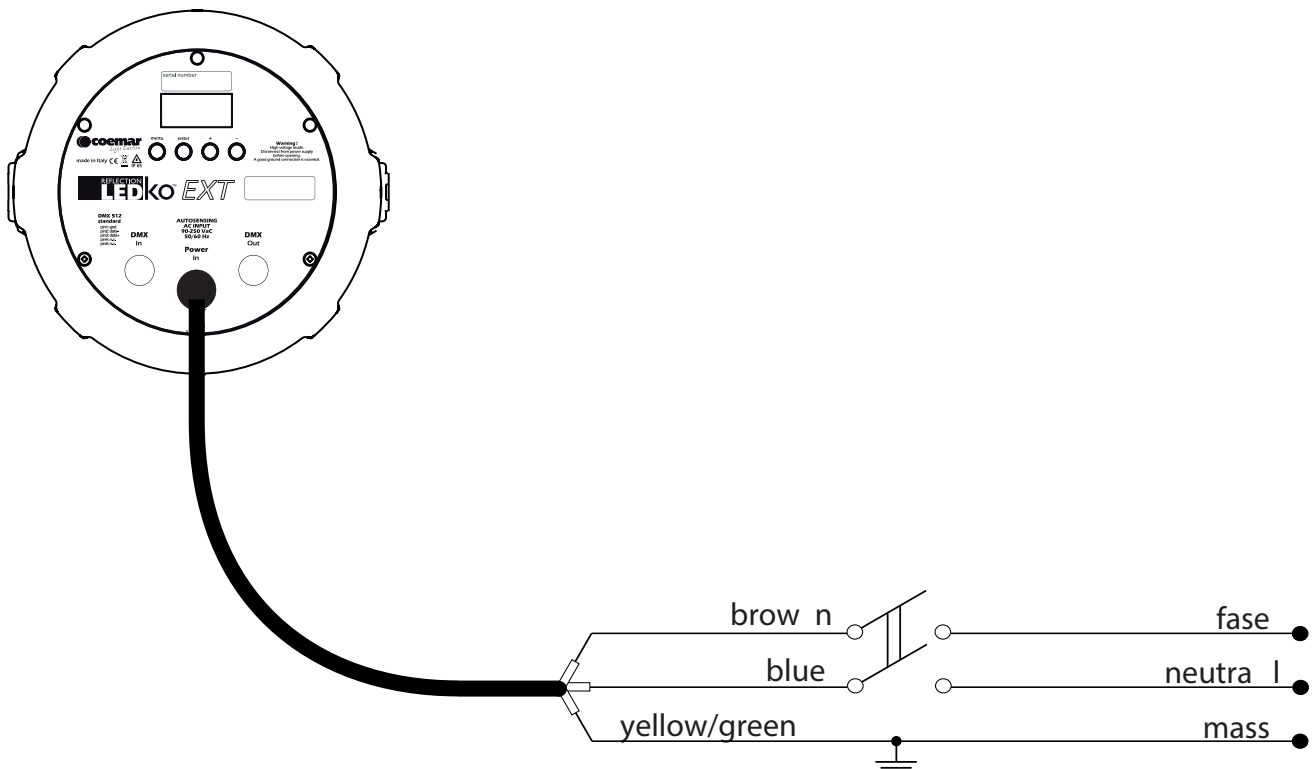

Warning!!

The use of a thermal/magnetic circuit breaker is recommended. Strict adherence to regulatory norms is strongly recommended.

LEDko EXT should not be powered through a dimmer as this may damage the internal switching power supply.

Prior to connecting the device to mains power, ensure that the mains characteristics are within the recommended range for the use of **LEDko EXT**.

All cabling and connections should be carried out by a suitably qualified personnel.

6. Control signal connections

6.1 Control signal connection by XLR5 plugs

The digital control signal is transmitted to the projector via a two pole cable screened as per International standards for the transmission of DMX 512 data. The connection must be serial, using connectors XLR5 male and female located on the back of **LEDko EXT** labelled DMX512 IN e OUT (see diagram).

Connectors equipped on **LEDko EXT** are IP rated, which ensures protection against water and dust. In order to keep this rating they must be connected exclusively to other IP rated connectors.

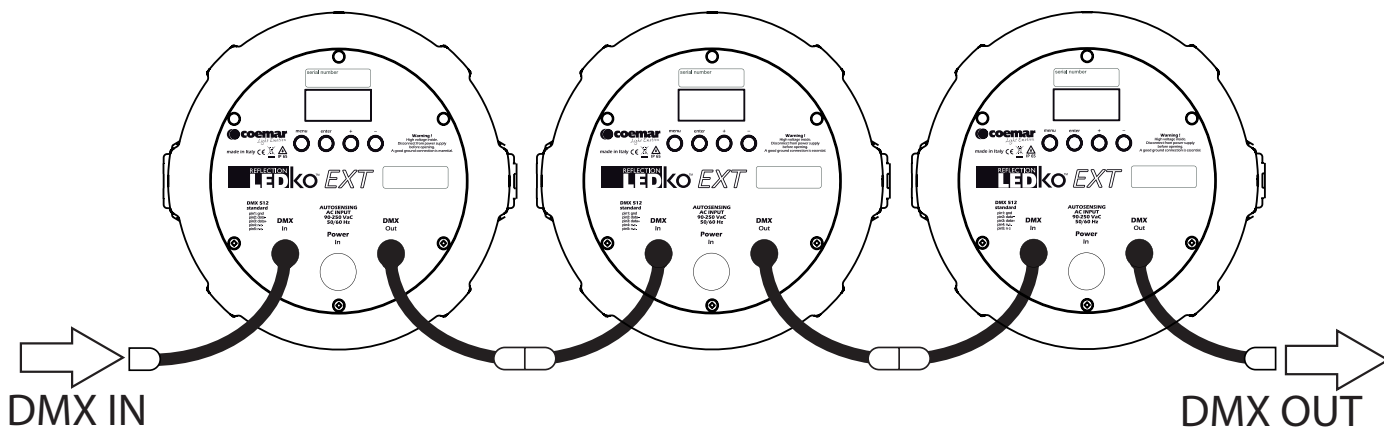

Warning!

Make sure that screening and conductors are not in contact one another or with the metal housing of the connector.

Pin#1 and housing never must be connected to the power supply unit.

7. Turning on the projector

After having followed the preceding steps described, proceed with the power supply and turn on the projector connecting it to the mains power.

The software version installed on the internal microprocessors will be shown on the display, suddenly it will show the current DMX addressing. If the address blinks, it means that the DMX signal has not been received. Check the connection cable and the mixer functioning.

7.1 DMX address of the unit

Each projector can use 8 or 4 address channels for its complete operation and is controlled by a DMX 512 signal.

DMX addressing

When powered up initially, each projector will show "A001", which indicates that the fixture will start responding from the first DMX channel; **LEDko EXT** also uses 8 DMX channels, which means that it will respond to the commands from channel 1 to channel 8 of your DMX 512 controller. Accordingly a second unit should be addressed as A009, a third one as A018 and so on. The operation must be carried out on every **LEDko EXT** which has an address different from A001.

Altering the DMX address:

1. Press the + or – button until the display shows the required DMX address. The digits on the display will blink to indicate that the variation has not been registered.
2. Press the enter key to confirm your selection. The digits on the display panel will cease to blink and the projector will now respond to the new address.

Note: by holding the + or – button down the scrolling will be faster; thus allowing a faster selection

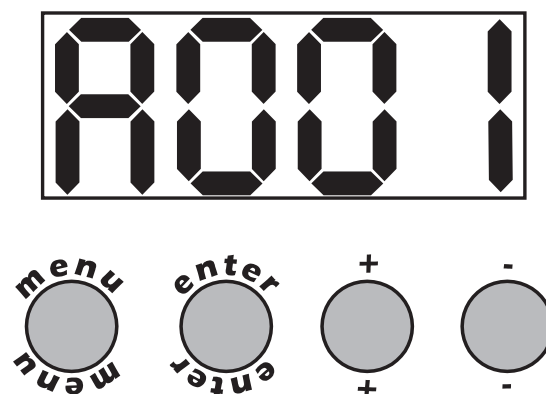

Warning!

If you alter the DMX address with no DMX signal connected, the digits on the display panel will continue to flash even after you have pressed ENTER button to confirm the address.

8. DMX chart

8.1 DMX Chart 8 channels

channel	function	type of control	effect	decimal	percentage
1	master dimmer	proportional	adjust luminous output intensity from 0 to 100%	0 - 255	0% - 100%
2	spare channel	step	no effect	0 - 255	0% - 100%
3	dimmer fine	proportional	fine dimmer control 16 bit	0 - 255	0% - 100%
4	strobe	step	no effect	0 - 9	0% - 4%
		proportional	variable speed strobing effect, from slow to fast	10 - 57	4% - 22%
		step	stop strobe	58 - 59	23% - 23%
		proportional	sequenced pulse effect, slow closing, fast opening (variable speed pulsing, from slow to fast)	60 - 108	24% - 42%
		step	stop strobe	109 - 110	43% - 43%
		proportional	sequenced pulse effect, fast closing, slow opening (variable speed pulsing, from slow to fast)	111 - 159	44% - 62%
		step	stop strobe	160 - 161	63% - 63%
		proportional	random strobe effect with variable speed from slow to fast	162 - 207	64% - 81%
		step	stop strobe	208 - 209	82% - 82%
		proportional	random strobe effect with variable speed from slow to fast	210 - 255	82% - 100%
5	special functions	step	no effect	0 - 9	0% - 4%
			600 Hz	10 - 84	4% - 33%
			fan at low-noise speed	85 - 96	33% - 38%
			fan at auto-silent speed	97 - 108	38% - 42%
		proportional	fan speed control	109 - 120	43% - 47%
		step	fan at maximum speed	121 - 133	47% - 52%
			enables the automatic display blackout	134 - 185	53% - 73%
			disables the automatic display blackout	186 - 199	73% - 78%
			LED control frequency tuning 1.000 Hz	200 - 205	78% - 80%
			LED control frequency tuning 3.000 Hz	206 - 211	81% - 83%
			LED control frequency tuning 6.000 Hz	212 - 217	83% - 85%
			LED control frequency tuning 8.000 Hz	218 - 223	85% - 87%
			LED control frequency tuning 10.000 Hz	224 - 229	88% - 90%
			LED control frequency tuning 12.000 Hz	230 - 235	90% - 92%
			LED control frequency tuning 14.000 Hz	236 - 241	93% - 95%
			LED control frequency tuning 16.000 Hz	242 - 247	95% - 97%
LED control frequency tuning 19.000 Hz	248 - 255		97% - 100%		

6	gobo rotation speed	proportional	adjust proportionally the speed of both gobos	0	-	255	0%	-	100%
7	speed gobo 1	step	gobo in stop	0		0%			
		proportional	control the gobo 1 speed counterclockwise (from fast to slow)	1	-	125	0%	-	49%
		step	gobo in stop	126	-	129	49%	-	51%
		proportional	control the gobo 1 speed clockwise (from slow to fast)	130	-	254	51%	-	100%
		step	gobo in stop	255		100%			
8	speed gobo 2	step	gobo in stop	0		0%			
		proportional	control the gobo 2 speed counterclockwise (from fast to slow)	1	-	125	0%	-	49%
		step	gobo in stop	126	-	129	49%	-	51%
		proportional	control the gobo 2 speed clockwise (from slow to fast)	130	-	254	51%	-	100%
		step	gobo in stop	255		100%			

8.2 DMX Chart 4 channels

channel	function	type of control	effect	decimal	percentage
1	master dimmer	proportional	adjust luminous output intensity from 0 to 100%	0 - 255	0% - 100%
2	gobo rotation speed	proportional	adjust proportionally the speed of both gobos	0 - 255	0% - 100%
3	speed gobo 1	step	gobo in stop	0	0%
		proportional	control the gobo 1 speed counterclockwise (from fast to slow)	1 - 125	0% - 49%
		step	gobo in stop	126 - 129	49% - 51%
		proportional	control the gobo 1 speed clockwise (from slow to fast)	130 - 254	51% - 100%
		step	gobo in stop	255	100%
4	speed gobo 2	step	gobo in stop	0	0%
		proportional	control the gobo 2 speed counterclockwise (from fast to slow)	1 - 125	0% - 49%
		step	gobo in stop	126 - 129	49% - 51%
		proportional	control the gobo 2 speed clockwise (from slow to fast)	130 - 254	51% - 100%
		step	gobo in stop	255	100%

9. Display panel functions

9.1 Quick guide to menu

To access the functions menus just press the MENU button. Then press + or – buttons to scroll the pages and press the ENTER button to access to any other function.

By suitably using all the functions of **LEDko EXT**, which can be activated through its display panel, it is possible to change some of the parameters and to add some functions. Changing the preset settings made by **Coemar** can vary the functions of the projector so that it will respond differently to the controller; therefore carefully read about the functions described here before carrying out any possible selection.

9.2 Rapid count

Through the display panel of **LEDko EXT** it is possible to quickly change the various numbers displayed for the different functions in the following 3 manners:

1. Pressing the + or – buttons will cause the count to be quicker.
2. Pressing first + and then – and then holding them down simultaneously will cause the numbers to jump to the highest value.
3. Pressing first – and then + and then holding them down simultaneously will cause the number to jump to the lowest value.

9.3 Quick dimmer menu

By pressing the enter button, the user will enter the quick dimmer menu: thanks to this menu it will be possible to increase and decrease the light intensity in steps of 10 (in a range from 0 to 100).

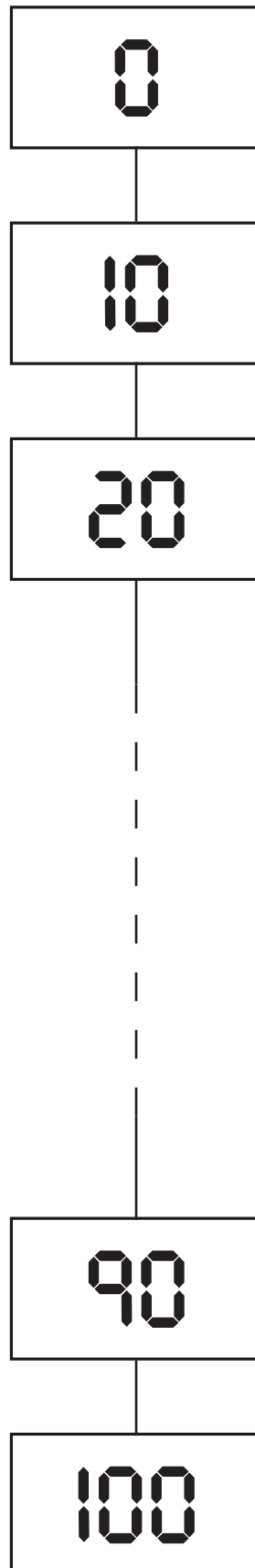

9.4 Main functions menu (FUNC)

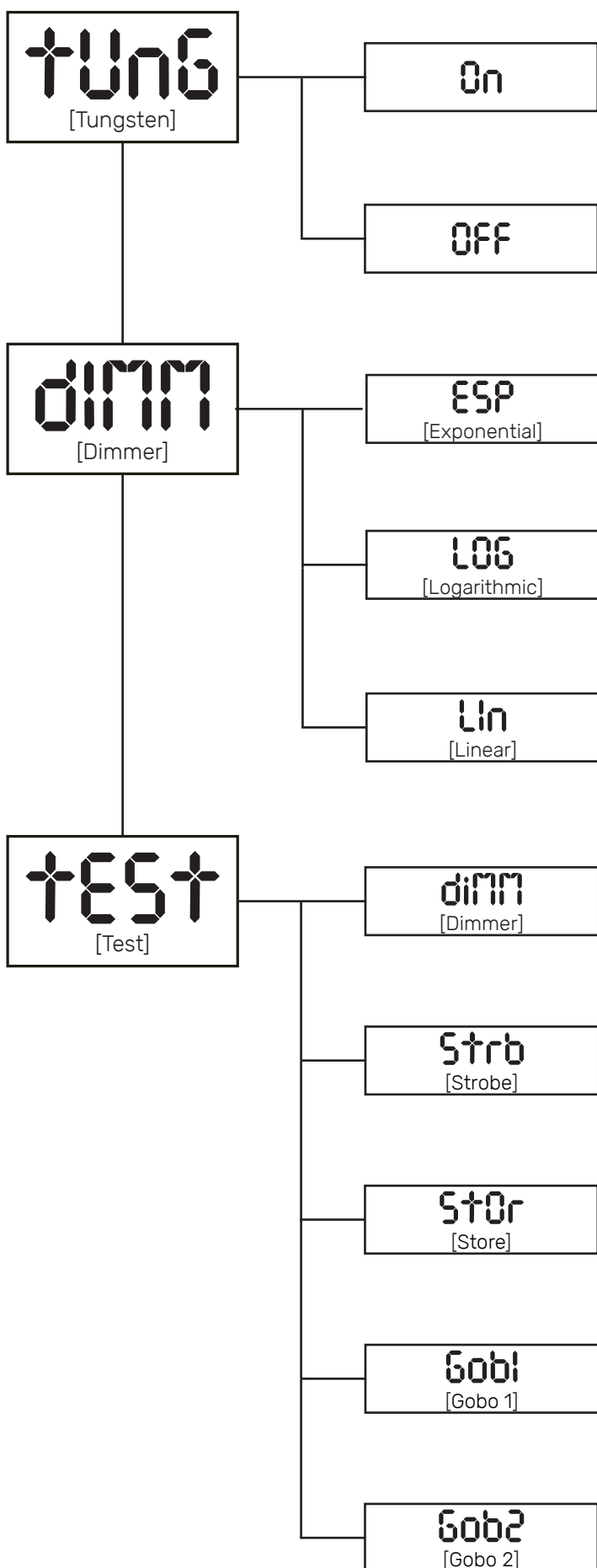

Tungsten:

Mimics the slow dimming curve of tungsten lamps.

Dimmer:

It allows the selection of different dimmer curves: exponential (default), logarithmic and linear;

Test:

Allows to manually set the DMX channels controlled by a DMX console:

- **Dimmer:** sets the luminous intensity;
- **Strobe:** manually sets the strobe DMX channel;
- **Store:** stores the modifications that will be set at the next times the fixture will be turned on.
- **Gobo 1:** choose manually the gobo 1 speed (from 0 to 255)
- **Gobo 2:** choose manually the gobo 2 speed (from 0 to 255)

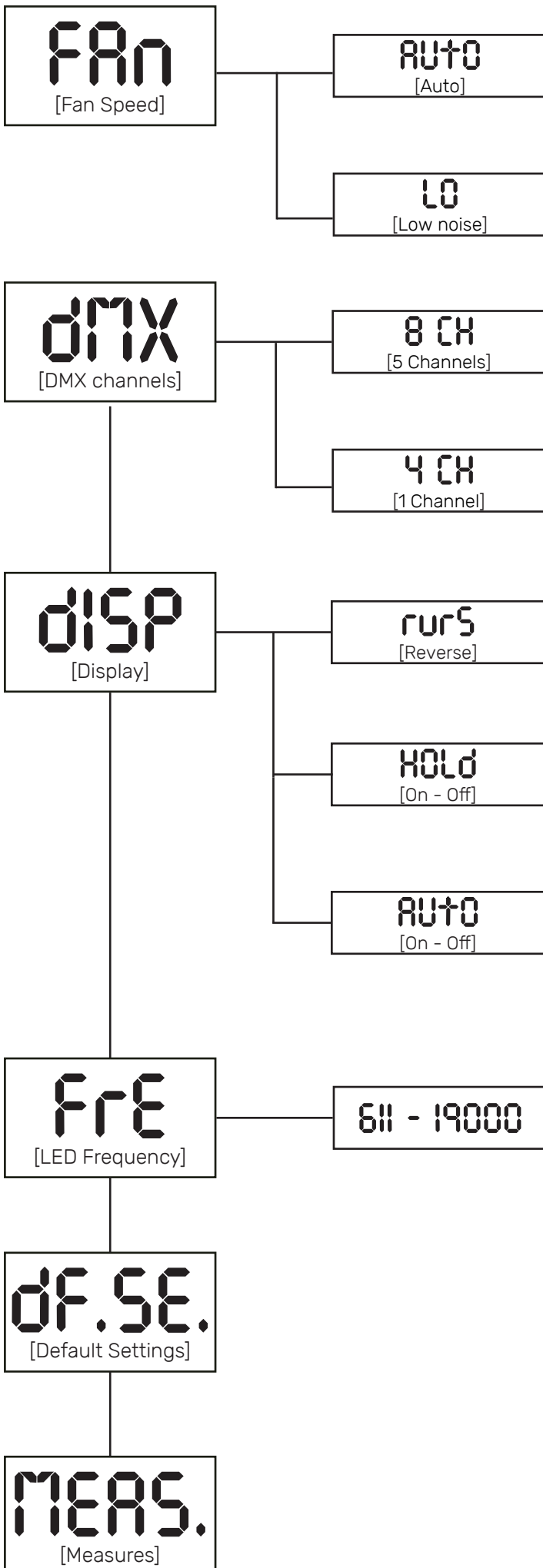

Fan Speed:

- **Auto:** under this setting the fan speed varies based on the overall temperature of the fixture to guarantee the maximum output possible;
- **Low noise:** this setting will keep the speed of the fan at the minimum level while the light output will decrease in case of overheat.

DMX channels:

Shows the DMX mode and number of channels selectable;

Display functions:

Changes the display settings:

- **Reverse:** rotates the display of 180°;
- **Auto:** Sets or disables the automatic display turn off function, which would occur after 10 seconds of inactivity;
- **Hold** Sets or disables the automatic display lock function that occurs after 10 seconds of inactivity;

Note: The AUTO and HOLD function become active only when the DMX address selection is displayed (A001). The effect of AUTO and HOLD trigger after 10 seconds of keyboard inactivity. To turn on the display it is enough to push a button, to unlock the keyboard it is necessary to hold any button down for a few seconds.

LED Frequency:

Allows to choose the operating frequency of the LEDs in order to avoid flickering issues with video recording devices. The excursion varies from 611 Hz (default) to 19000 Hz.

Default Settings:

It restores all the settings to default value except for led settings, hour and DMX address.

Measures:

Allows to read all the parameters: LED and board temperatures, fan level, DMX ratio, DMX, alarms, channels value and software version.

9.5 Measures menu (MEAS)

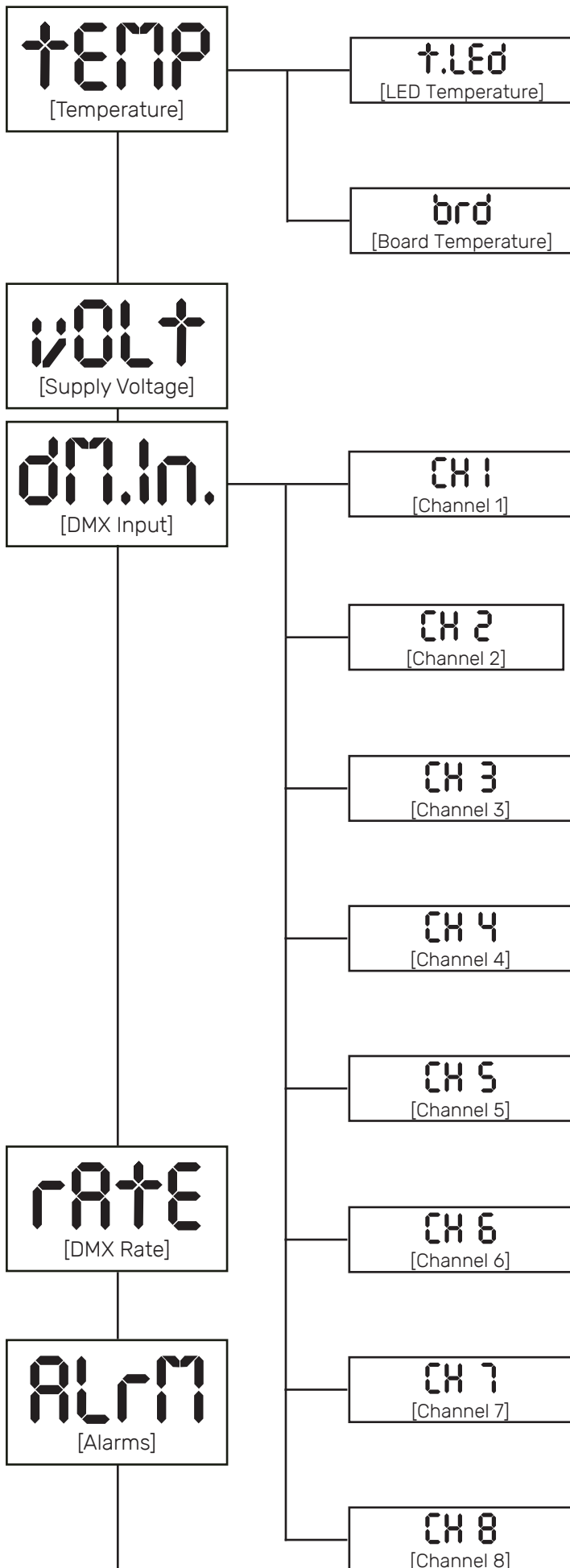

Temperature:

Shows the current temperature values:

- **LED:** shows the LED module temperature;
- **Board:** shows the electronic board temperature.

Volt:

Shows the power supply voltage.

DMX Input:

Shows the value of the DMX channels received by the fixture on every channel that the fixture occupies on the line.

Rate:

Shows the refresh rate of the DMX signal sent by the console

Alarm:

This menu shows the alarm statuses if there is any.

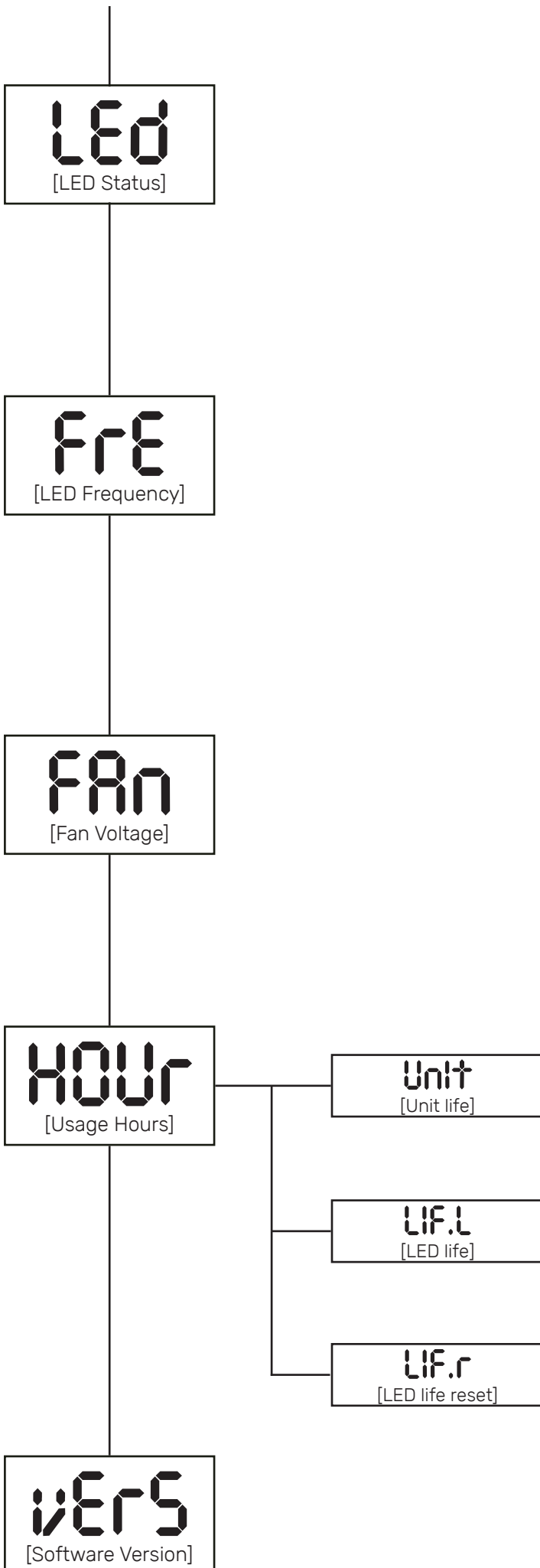

LED:

Shows the percentage value of the LED status.

Fre:

Shows the operating frequency of the LED (611 Hz as default).

Fan speed:

Shows the voltage in which the fan is operating

Usage hours:

Shows the hour counter of the fixture:

- **Unit:** shows the overall hours of life of the fixture;
- **LED life:** shows the overall LED module life;
- **LED life reset:** shows the overall LED module life currently installed.

Note: this items can be reset in case of LED module replacement;

Software version:

Shows the software version currently installed in the fixture.

9.6 Electronic alignment of the leds

The display panel of **LEDko EXT** allows the electronic alignment of the LEDs, this procedure is performed by **Coemar** at the time of testing, this procedure may be useful for special effects or in case of replacement of internal components (PCBs, LEDs, etc...).

Altering the settings made by **Coemar** may radically alter the operation of the projector's functions. Carefully read the following prior to attempting any changes.

Warning!!

This chapter should be considered for the exclusive use of technicians and qualified personnel.

Warning!!

This menu can only accessed in the **DF.SE.** [Default Settings] menu by pressing at the same time **ENTER** and **MENU** buttons. This menu shall be accessed only by authorized technicians.

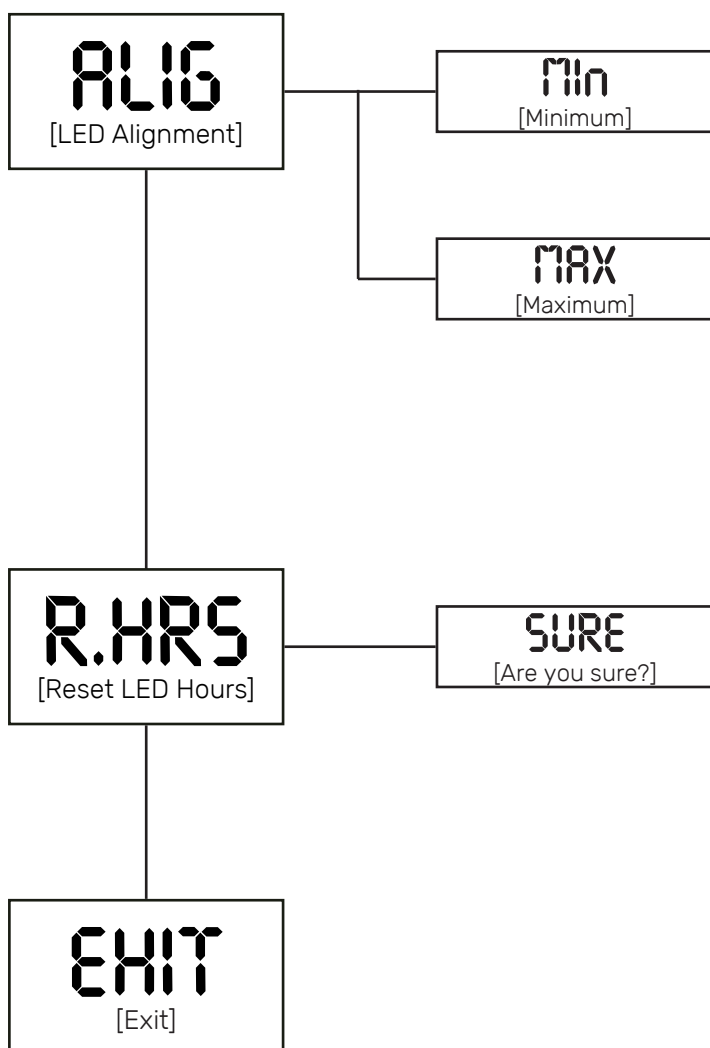

LED alignment:

This item allows to align the minimum and the maximum level of intensity of the LEDs:

- **Minimum:** raise or lowers the minimum intensity to level the dimming between the fixtures;
- **Maximum:** aligns the maximum output level between each fixture;
- **Exit:** exits the menu and stores the changes;

Reset hours:

Allows to erase the hours of operation of the LED module in case of replacement;

9.7 Special functions of the fixture

Storing the DMX signal

To use the fixture without an active DMX console it is possible to store the DMX settings in two ways:

- Through the **TEST** menu;
- Disconnecting the DMX signal when the fixture is on. When the signal is unconnected the fixture stores the signal;

Automatic fan standby

To decrease the noise and the power consumption the cooling fan turns off after 10 minutes of fixture inactivity.

9.8 Error messages

If a malfunction occurs, **LEDko EXT** has a self-diagnostic system that will show the error message on the display. The following table will explain in detail the most common errors. If, despite of suggested intervention, the problem persists, call the **Coemar** Service Center.

Error code	Description
noal [No Alarm]	No Alarm The projector self-diagnostic routine didn't find any issue.
DTER [Data Error]	Data error Initial data loading has failed the projector loaded the default data settings: restart the fixture again, and if the error persists contact the Coemar assistance center.
ADER [Address Error]	Address error The projector does not receive all channels of DMX needs to function properly. Check the DMX address indicated on the display and the number of channels generated by the mixer control. We recall in this connection that some controllers do not generate all the 512 channels.
LED [LED Error]	LED error Auto diagnostic routine found that the LED module may damaged, contact Coemar assistance for the module replacement. IMPORTANT: To ensure the sensor is giving correct readings, set the LED to the maximum light output level.

10. Accessories and Spare parts

All the components of **LEDko EXT** are available as spare parts from your **Coemar** dealer or Service. Accurate description of the fixture, model number and type will assist us in providing for your requirements in an efficient and effective manner.

Accessory name	Code
Small yoke	357LAM_036
Side handle	MA05

11. Maintenance

11.1 Firmware update

The firmware of **LEDko EXT** can be updated through the RDM protocol (ANSI E1.20). Contact **Coemar** assistance to receive the software and the device updater.

11.2 Periodic cleaning

Lenses

Even a thin layer of dust can reduce the luminous output and alter the consistency of the beam. Regularly clean all filters and lenses using a soft cotton cloth, dampened with a special lens cleaning solution.

Cleaning of the unit

Use a soft brush or a common vacuum cleaner or a source of compressed air for removing dust. For the cleaning of the housing use a soft cloth and a non-aggressive cleaner. Check that the internal fans and heat exchanger must be perfectly clean.

11.3 Periodic controls

Mechanical components

Check the correct working of the mechanical parts and, if needed, replace them. Make sure the projector is not mechanically damaged. If necessary, replace the worn parts.

Electrical components

Check all electrical connections, in particular for correct grounding and correct attachment of all extractable connectors. Press the connectors if necessary and reposition as before.

11.4 Fuses

LEDko EXT has an automatic fuse that in most cases does not need to be replaced.

12. F.A.Q. and answers

The following list shows common issues that may be simply solved. If issues persist, the unit must be repaired by a qualified personnel or just contact your **Coemar** service.

Question	Possible solution
LEDko EXT does not emit light	Projector not powered on: <ul style="list-style-type: none">• Make sure the power cable is plugged in or test the input voltage; Wrong DMX address: <ul style="list-style-type: none">• Check the DMX Address setting and the output signal of the controller;
LEDko EXT is not responding to DMX signal	DMX signal may not reach LEDko EXT: <ul style="list-style-type: none">• Inspect the cable connection, correct poor connections or inefficient repair or replace damaged cables;• Check DMX address of the unit;



Information on disposal of the equipment

The equipment at the end of its useful life must be disposed of at an appropriate recycling center for waste electrical and electronic equipment. The treatment and disposal of environmentally friendly, helps prevent potential negative environmental and health and promote the reuse and / or recycling of materials making up the equipment. Illegal disposal by the user includes the application of administrative sanctions provided by law.



Coemar Lighting s.r.l.

Via Carpenedolo 90
46043 Castiglione delle Stiviere, Mantova, Italy
phone. +39 0376/1514412 - fax +39 0376/1514380
info@coemar.com

Coemar reserves the right to change specifications without prior notice