



LEDko EXT D

Product code: F029F001A (CRI 80) | F029D001A (CRI 90)

KEY FEATURES

- LED profile spot IP 65
- Daylight COB LED (CRI 80 - CRI 90)
- Profile zoom from 14° to 35°
- Four blade framing system and internal gobo holder
- Electronic 16 bit dimming with 3 selectable curves (Exponential, Logarithmic and Linear)
- Fan setting with 2 different options (Auto, Silent)
- Guaranteed flicker-free



SPECIFICATIONS

- Fixed white CCT: 5,600 K
- IP rating: 65 (weatherproof)
- Profile zoom from 14° to 35°
- Four blade framing system, each shutter blade is adjustable for radial position and angle
- Internal gobo holder (standard gobo size B)
- Electronic 16 bit dimming with 3 selectable curves (exponential, logarithmic or linear)
- Synchronized, random or pulse electronic strobe
- Flicker-free operation with LEDs frequency controlled via DMX from 600 to 19,000 Hz
- Fan setting with 2 different options (auto, silent)
- CE approved

LIGHT SOURCE

- Daylight COB LED (CRI 80 or CRI 90)
- Average LED lifetime: a minimum of 80% of the initial luminous flux will be maintained after approx. 50.000 hours of usage (50.000 LM80)

PHYSICAL SIZE

- Length: 687.8 mm (27.07 in)
- Width: 252.6 mm (9.94 in)
- Height: 248 mm (7.0 in)
- Height with bracket: 405 mm (15.94 in)
- Weight: 14.0 Kg (30.8 lbs)

CONTROL PROTOCOL AND PROGRAMMING

- USITT DMX512A
- DMX channel: 5 / 1
- Setting, addressing, testing and measurements via LEDs display
- RDM (Remote Device Management)

ELECTRICAL SPECIFICATIONS AND CONNECTIONS

- AC power: 85-264 V, auto-sensing, 50/60 Hz
- Internal cable without power plug
- Max power consumption: 200 W
- Power consumption: 0.92 A at 230 V, 1.83 A at 115 V - $\cos\phi$ 0,95
- DMX data in/out: 5 pin locking XLR

DRAWING SIZE

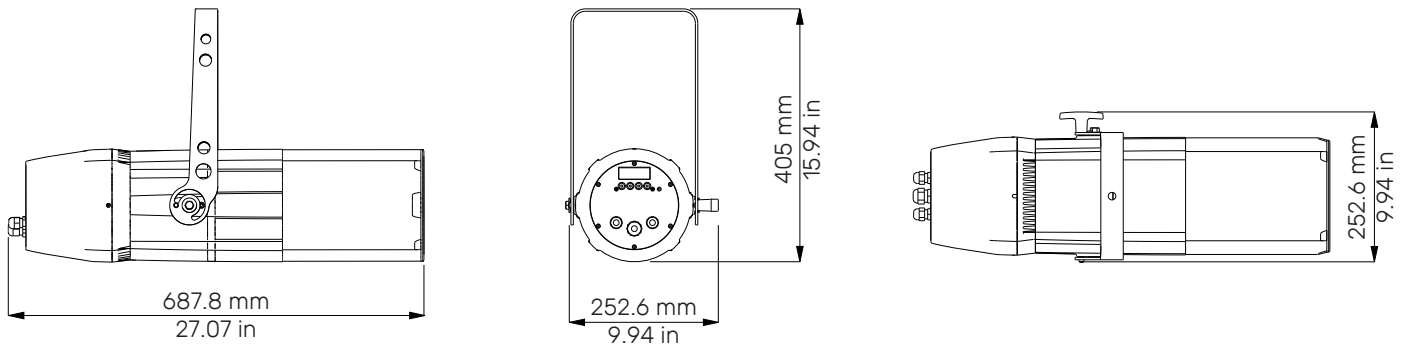

DMX CHARTS

5 channels	
1	master dimmer
2	spare channel
3	dimmer fine
4	strobe effect
5	special function

1 channel	
1	master dimmer

PHOTOMETRIC DATA

The LEDko EXT Photometric Data may be downloaded from www.coemar.com.